

# 产品尺寸图 (DIMENSION)

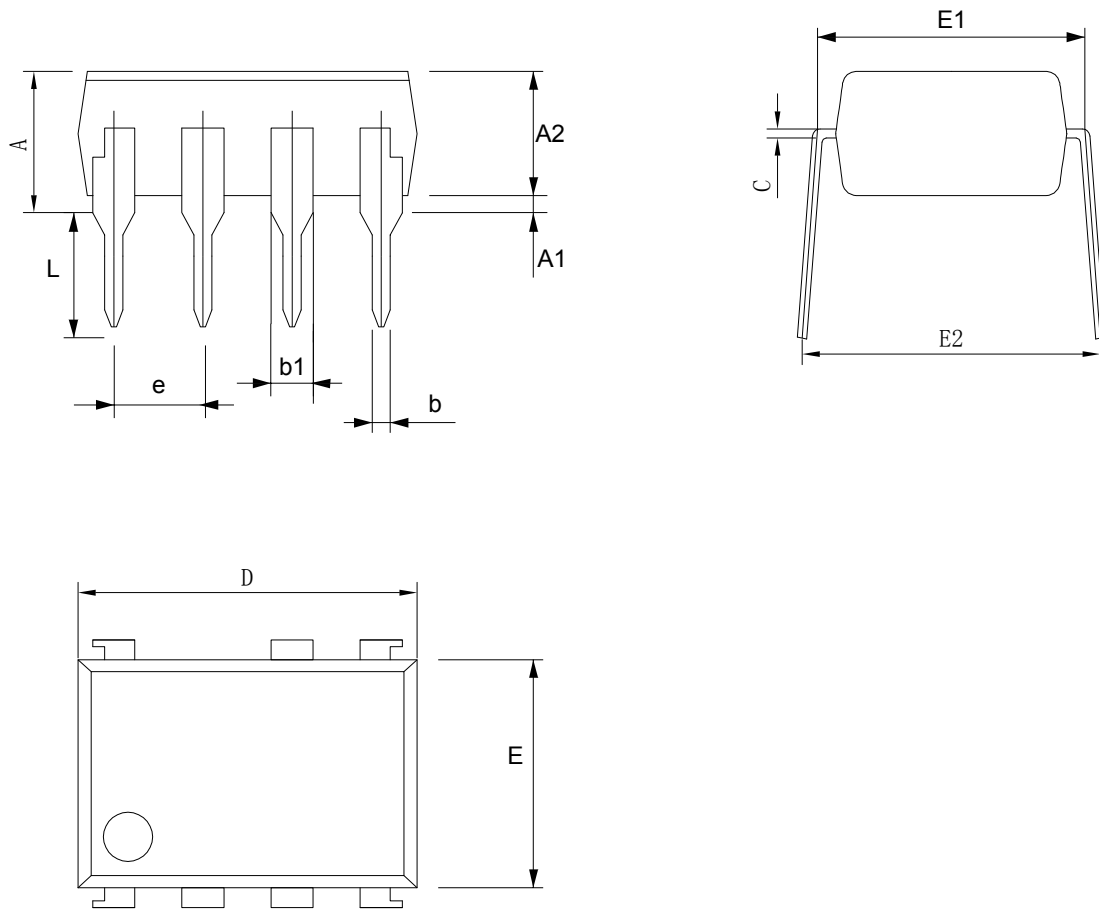

symbol	Dimensions In Millimeters			Dimensions In Inches		
	Min	Nom	Max	Min	Nom	Max
A	3.50	4.00	4.50	0.138	0.157	0.177
A1	0.50 TYP.			0.020 TYP.		
A2	3.20	3.50	3.80	0.126	0.138	0.150
b	0.40	0.50	0.60	0.016	0.020	0.024
b1	0.90	1.20	1.50	0.035	0.047	0.059
C	0.16	0.26	0.36	0.006	0.010	0.014
D	9.16	9.66	10.16	0.360	0.380	0.400
E	6.00	6.50	7.00	0.236	0.256	0.276
E1	7.32	7.62	7.92	0.288	0.300	0.312
E2	8.20	8.50	8.80	0.323	0.335	0.346
e	—	2.54	—	—	0.100	—
L	2.85	3.15	3.45	0.112	0.124	0.136

# FSMC

图名 NAME	DIP-8A		图号 DWG. NO.	DD0068	SH 1 OF 1
材质 MATERIAL	Cu		REV.	A	
单位 UNITS	mm [INCH]	核准 APPROVE	审核 CHECKED	制图 DRAWN	 第三角法
日期 DATE	2018-01-17				
比例 SCALE	N. T. S.				